

ARF27

7243B & 7244A

User Guide

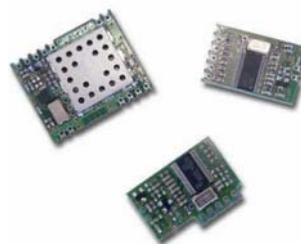

GENERAL PRESENTATION	2
SYNOPTICS	2
SPECIFICATIONS	3
<i>Transmitter</i>	3
<i>Receiver</i>	3
<i>Complete Set</i>	3
PRODUCT INTERFACE	4
<i>Transmitter</i>	4
<i>Size / Electric Pin assignment</i>	4
<i>Notes</i>	4
 <i>Receiver</i>	5
<i>Size / Electric Pin assignment</i>	5
<i>Notes</i>	6

GENERAL DESCRIPTION

The ARF7243B module is a Xtal based reference 869.525MHz FSK transmitter. Its power is adjustable with a maximum of 500mW on 50 ohms. This transmitter is compatible with any FSK receiver able to handle FSK +/-25KHz modulations as the ARF7244A (description enclosed)

The ARF7244A receiver is a very high sensitivity (1uV / -107dBm) FSK single heterodyne receiver.

It could function with all the FSK +/-25KHz Xtal based transmitter (bandwidth: 100kHz).

These modules are supplied without antenna. To increase the performances, we recommended the use of a « Whip » Antenna.

All these modules build rough radio link, bit coding and frame coding has to be managed by associated digital controller.

They are available as subassembly daughter board to complete an electronic digital motherboard.

SYNOPTICS

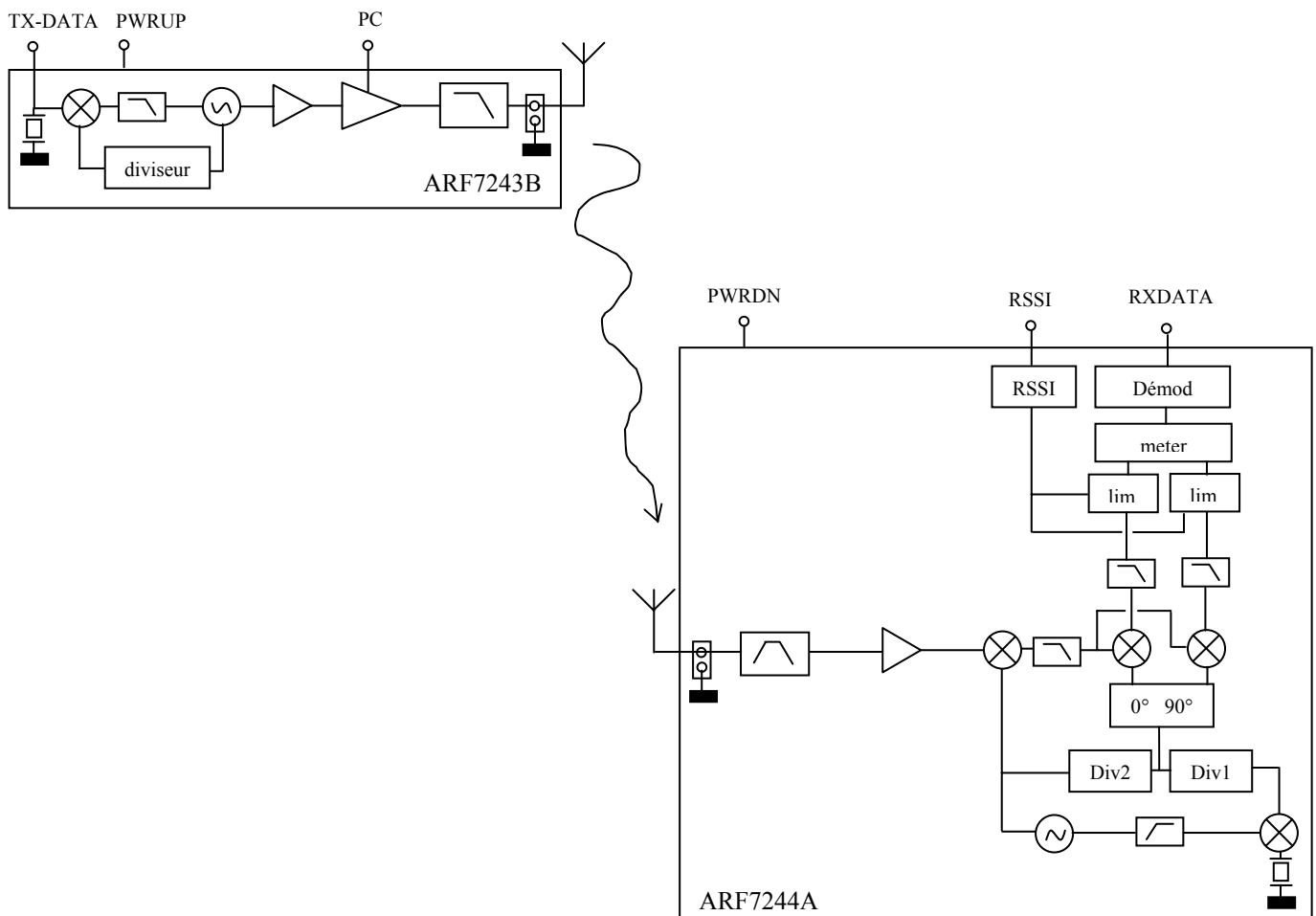

SPECIFICATIONS

- Transmitter

Parameters	Values	Notes
Operating frequency	869.525 MHz	-
Conducted power	from 25 mW (+14dBm) to 500mW (+27dBm)	on 50Ω and at 5V
Modulation	FSK ± 25 kHz	-
Operating voltage (VCC)	From 2,7V to 5V.	
Digital input levels	0 / VCC	-
Consumption	from 150 mA to 600mA	-
Standby current	<10 μA	-
Start time	2 ms	-
Pinning	see chapter 4.1	-
Size	24,1 x 30,2 x 11 without antenna	-

- Receiver

Parameters	Values	Notes
Frequency	869.525 MHz	-
Sensitivity	1μV (-107dBm)	On 50Ω
Demodulation	FSK ± 25 kHz	-
Bandwidth	100 kHz	-
Operating voltage (VCC)	from 2.2V to 5V	
Serial digital output	0 / VCC	-
Consumption	10 mA 12mA	At 3V At 5V
Standby current	<1 μA	-
Start time	5 ms	-
Pinning	see chapter 4.2	-
Size	25 x 16 x 7 without antenna	-

- Complete set

Parameters	Values
Link settling time	2.5ms
Range	3000m
Binary rate	from 500 to 10000 bps Manchester
Temperature	from -20°C to +70°C
Standards	Radio: EN300220 CEM: EN301489

PRODUCTS INTERFACE

- Transmitter

Size / Electric pin assignment

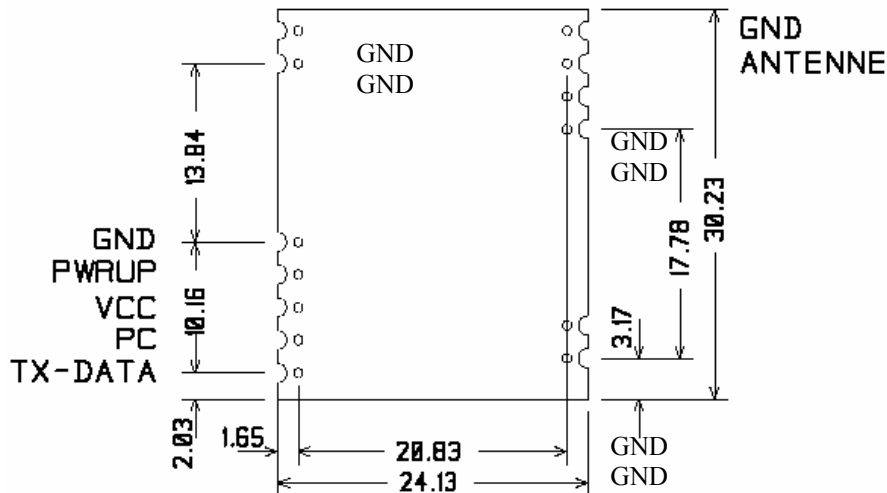

- **PC:** Management of the product power.
- **TX-DATA:** Data input.
- **PWRUP:** power up input

Notes:

- Dimensions are given in mm.
- Antenna & connectors (2.54mm pitch) non-supplied.
- Radio module has to be powered using an external power supply connected between VCC and GND. Operating voltage has to be in the 2 – 5V range. The maximum power is obtained through a 5V operating voltage.
- Power is trigged using the PWRUP pin:
 - PWRUP = "1" → Transmitter on.
 - PWRUP = "0" → Transmitter off.
- When in standby mode, « TX-DATA » pin has also to be logical "0".
- The PC pin (Power_Control) allows the modification of the transmitter power. The diagram gives a view of the power evolution regarding the operating voltage on the POWER_CONTROL:

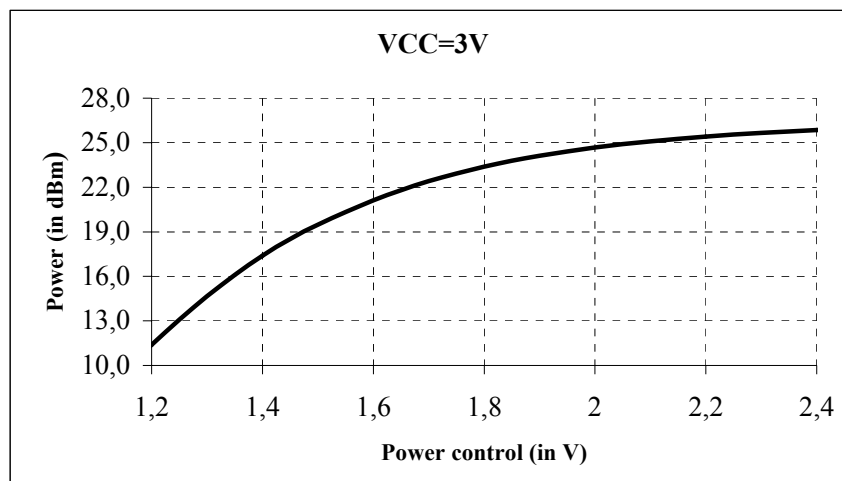

- When the Power_control pin is non connected, le product gives its maximum power (more or less 1 dB). The diagram gives a view of the product typical evolution regarding the operating voltage (Power_control pin non connected):

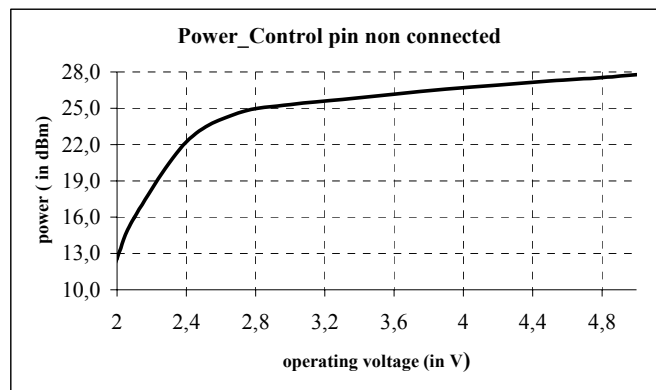

- **Receiver**

Size / Electric pin assignment

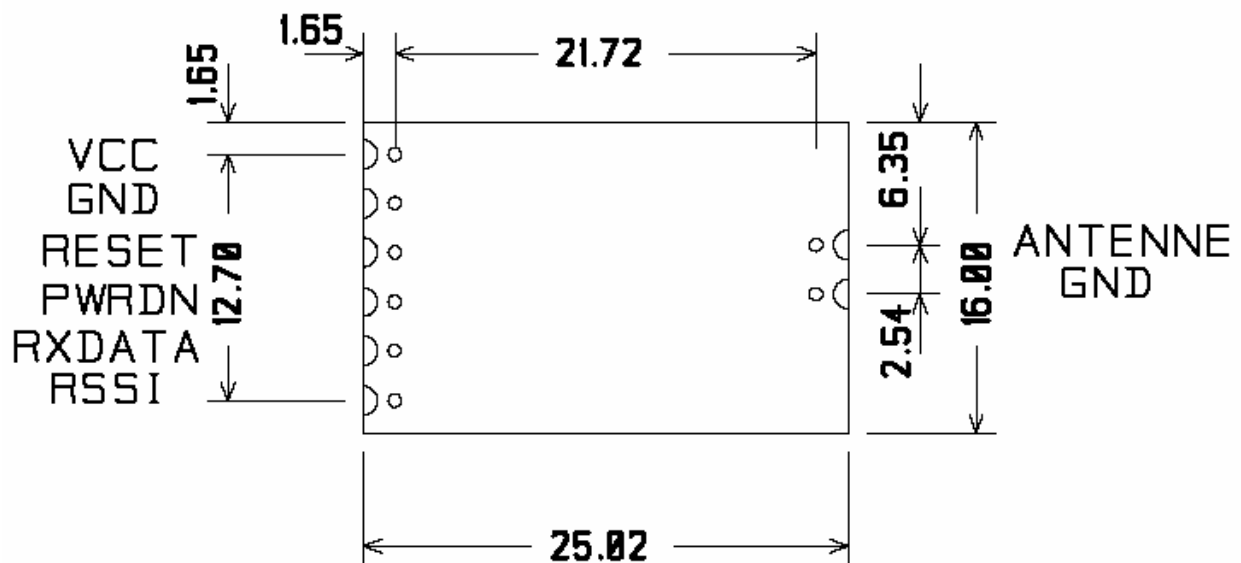

- RESET:** Non connected
- PWRDN:** Operating / stand by mode
- RXDATA:** Data output
- RSSI:** Received signal strength indicator.

Notes:

- Dimensions are given in mm.
- Antenna and connectors (2.54mm pitch) non-supplied.

Notes

- Radio module has to be powered using an external power supply connected between VCC and GND. Operating voltage has to be in the 2.2 – 5V range.
- Power is triggered using the PWRDN pin:
 - PWRDN = "0" → Receiver on.
 - PWRDN = "1" → Stand-by.

ATTENTION: If using a pull down resistor on PWRDN, its value has to be less than 220 Ohms!

If the receiver stand-by mode is activated immediately after powering up the equipment, please use timings below (for good receiver IC internal Reset).

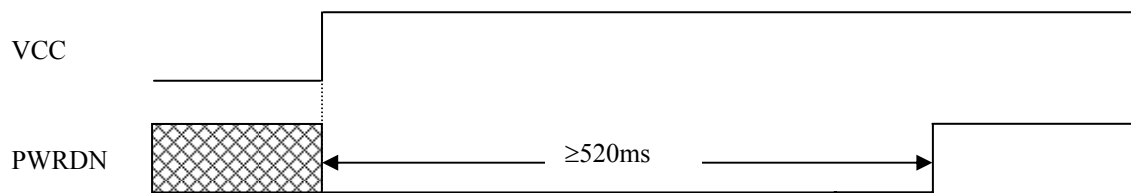

- The RSSI output allows seeing the RF input level. The diagram gives a view of the RSSI power evolution regarding the RF input level:

