

ARF18

ARF7294

User Guide

DECLARATION OF CONFORMITY		2
OVERVIEW		3
INTERFACE		4
<i>Mechanical interface</i>	4	
<i>Electrical interface</i>	4	
MODULE INTEGRATION		6
<i>PCB connection when learning control switches are used</i>	6	
<i>PCB connection when learning control switches are not used</i>	6	
<i>Digital outputs</i>	7	
<i>Serial link TxD and RxD lines</i>	7	
NORMAL MODE		8
<i>Data format on serial link</i>	8	
<i>Flip flop and monostable outputs behaviour</i>	8	
<i>Remote control acknowledgement</i>	8	
<i>Remote control serial number update</i>	9	
<i>Serial link configuration</i>	9	
LEARNING MODE		9
COMMANDS		9
SET OF COMMANDS		10
REGISTERS DESCRIPTION		10
SPECIFICATIONS		11
<i>General characteristics</i>	11	
<i>Transmitter characteristics</i>	11	
<i>Receiver characteristics</i>	11	
<i>Reference</i>	11	
STANDARD COMPLIANCE		12

DECLARATION OF CONFORMITY

according to ISO/IEC Guide 22 and EN45014



Manufacturer's name: **ADEUNIS R.F.**

Manufacturer's address: Parc technologique PRE ROUX IV
283 rue Paul Louis NEEL
38920 CROLLES - FRANCE

declares that the product

Product Name: 869.525 MHz FSK Transceiver Module

Product Number(s): ARF7294

Product options:

conforms to the RTTE Directive 99/5/EC :

EMC: conformity is proven by compliance to the standard EN 301489 according to the requirements of EMC Directive 89/336/EEC.

Safety: conformity to the standard EN 60950 according to the requirements of Low Voltage Directive 73/23/EEC.

Radio: conformity is proven by compliance to harmonised standard EN 300220 covering essential radio requirements of the RTTE directive.

Notes:

- Conformity has been evaluated according to the procedure described in Annex III of the RTTE directive.
- The use of the spectrum is harmonised by the fact that the product never falls in one of the restrictions listed in appendix 3 (Annex 1, band E) of the CEPT recommendation 70-03.
- Receiver class (if applicable): 3.

Crolles, March 06th, 2006

VINCENT Hervé / Quality manager

OVERVIEW

ARF7294 module is a bidirectional (transmitter and receiver) module to use with AR7292 bidirectional remote control. On detection of remote control frame, the ARF7294 sends the serial number and the key number of the remote control received on the serial link. The receiver can also drive up to 4 digital outputs if the serial number is recognized by the receiver (a learning mode procedure allows the receiver to learn the associations between remote control and output of the receiver).

Main features of ARF7294:

- Asynchronous serial transmission on remote control serial number reception
- Up to 4 digital outputs driven by any remote control and key (after a learning phase of the receiver)
- Flip-flop or monostable behaviour of the 4 digital outputs controlled by 2 inputs (1 input drives 2 digital outputs)
- Up to 18 remote controls stored in module memory
- Learning procedure using switch inputs or serial lines
- Automatic generation of an acknowledgement frame sent back to the remote control with LED control on remote command
- Generation of an acknowledgement frame by serial command with LED control on remote command
- Asynchronous transmission configuration from 1200 bps to 57600 bps
- All functionalities and configuration available by a set of serial commands.

INTERFACE

• Mechanical interface

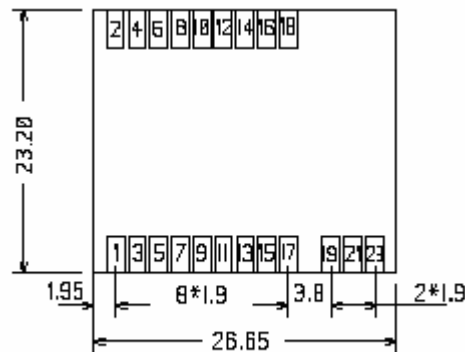

• Electrical interface

Pin number	Pin name	I/O direction	Description
<i>Power supply</i>			
1, 17, 18	GND		Digital GND (same as RF GND)
2	VCC		Power supply
<i>RF antenna interface</i>			
19	GND RF		RF GND (same as digital GND)
21	RF in/out		RF antenna.
23	GND RF		RF GND (same as digital GND)
<i>Digital transceiver output</i>			
3	DO1	O	Digital output 1
13	DO2	O	Digital output 2
11	DO3	O	Digital output 3
9	DO4	O	Digital output 4
4	LED	O	LED for learning mode process.
<i>Mode selector inputs</i>			
15	Add/Remove	I	Selects the Add/Remove functionality. This input must not be left disconnected. It is mandatory to connect to VCC to use the module in normal mode. Refer to “Remote control learning process” in the User guide for details.
6	Erase	I	Selects the Erase functionality. This input must not be left disconnected. It is mandatory to connect to VCC to use the module in normal mode. Refer to “Remote control learning process” in the User guide for details.
16	Sel0	I	Selects the Digital I/O to program when “Add/Remove” or “Erase” mode is selected. Selects the behaviour (monostable or flip-flop) for DO1 and DO2 when the

			receiver is in normal mode. This input must not be left disconnected. It is mandatory to connect to VCC (flip-flop mode) or to GND (monostable mode) if the transceiver is using the Digital Outputs 1 or 2. In any other case, it is mandatory to connect to GND. Refer to “Remote control learning process” in the User guide for details.
14	Sel1	I	Selects the Digital I/O to program when “Add/Remove” or “Erase” mode is selected. Selects the behaviour (monostable or flip-flop) for DO3 and DO4 when the receiver is in normal mode. This input must not be left disconnected. It is mandatory to connect to VCC (flip-flop mode) or to GND (monostable mode) if the transceiver is using the Digital Outputs 1 or 2. In any other case, it is mandatory to connect to GND. Refer to “Remote control learning process” in the User guide for details.
12	Global	I	Selects the global feature when the “Add/Remove” or “Erase” mode is selected. Even if the learning mode are not used, it is mandatory to connect this input to GND.
<i>Asynchronous serial interface</i>			
7	RxD	I	Serial input. It is mandatory to drive this input. (apply VCC if the serial link is not used).
8	TxD	O	Serial output. It is strongly recommended to tie this output to VCC with a pull-up resistor (47kΩ for example).

Important note: Directions are given from RF module point of view.

MODULE INTEGRATION

The module can be used either with digital outputs or with a serial interface. Both interfaces can also be used simultaneously.

The learning procedure can be performed either by serial interface or by the set of dedicated switch inputs.

The module does not integrate any pull-up or pull-down on digital I/O interface. External pull-up or pull-down resistors must be added.

Reports to the “ARF18 remote control learning process” document for detailed explanations about the learning procedure.

• PCB connection when learning control switches are used

When the learning process has to be performed by switches, the following scheme has to be used for the following inputs: Sel0, Sel1, Global, Add/Remove and Erase. The pull-up resistor can be set with a 47k Ω value.

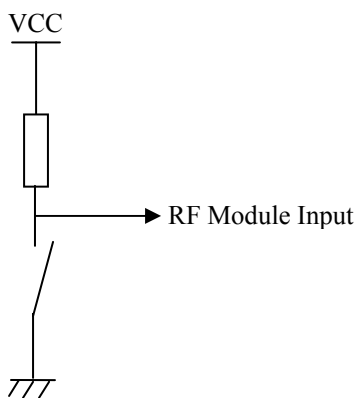

The LED output of the module can be used to connect a LED which is used during learning phases. It is strongly recommended to connect a LED on this output to help users during learning operation of the product. The LED has to be connected according to the following scheme. The resistor has a minimum value to ensure a current max of 6 mA under 3 V.

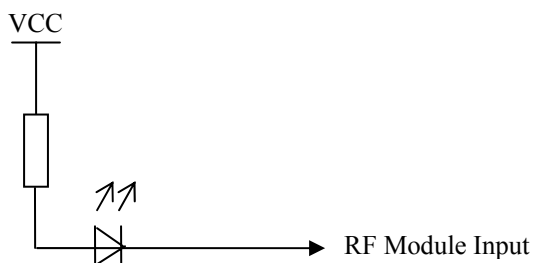

• PCB connection when learning control switches are not used

- When the learning process is not performed by switches or no learning process is performed at all because digital outputs are not used, **it is mandatory to connect**

Add/Remove and Erase inputs to VCC. Global input can be connected either to VCC or to GND.

- If digital outputs 1 and 2 (DO1 and DO2) are not used, **it is mandatory to connect Sel0 to VCC**. The same rule must be applied if digital outputs 3 and 4 (DO3 and DO4) are not used: In this case **Sel1 must be tied to VCC**.
- When digital outputs are used, Sel0 for digital outputs 1 and 2 (DO1 and DO2), Sel1 for digital outputs 3 and 4 (DO3 and DO4) must be connected to VCC to allow the outputs to act as flip-flop output (one key pressed on remote control toggles the output level) or has a monostable output (the output is set to VCC while the remote control key is keep pressed).

• Digital outputs

Digital outputs can be connected to a transistor to drive any kind of system. These digital outputs are controlled according to the remote control learned by the transceiver and the 2 inputs Sel0 and Sel1 which select the behaviour of the output (Sel0 inputs select the behaviour of Digital output 1 and 2, Sel1 is used for Digital outputs 3 and 4). When Sel0/Sel1 are tied to VCC the outputs act as flip-flop (one key pressed on remote control toggle the output level). When tied to GND, they act as monostable outputs (the output is set to VCC while the remote control key is keep pressed).

• Serial link TxD and RxD lines

Neither TxD nor RxD are tied on the RF module.

- **If serial lines are not used, the RxD line should be tied to VCC.**
- **If serial lines are used, it is strongly recommended to add a pull-up resistor on TxD and RxD lines** because these lines are not driven while microcontrollers are not initialized. If not added, it can result in invalid characters for the receiver so that the next valid command could not be interpreted.

NORMAL MODE

When in normal mode, the receiver transmits on its serial line each remote control key pressed received. The digital output lines, if any configured, are driven according to the Sel0 and Sel1 inputs and an acknowledgement is sent back to the remote control if automatic acknowledgment has been selected.

• Data format on serial line

On remote control key reception, the receiver sends on the serial line the serial number and the key number of the remote control received on its radio link. The format of the ASCII received frame is the following:

:<serial number> <Key number><CR><LF>

- Serial number is the remote control serial number in decimal format (1 to 8 digits)
- Key number is the pressed key number of the remote control (2 digits with first digit = '0' and second digit = '1' or '2' or '3' or '4').

The transmission on the serial line of serial number + key number received does not depend on the learning process and remote control recorded in receiver data base. All remote control received is sent on serial line.

• Flip flop and monostable outputs behaviour

The digital outputs (if any configured for this remote control key) are driven according to the Sel0 and Sel1 inputs. Reports to "Module integration" chapter at the "digital outputs" section and to the "ARF18 remote control learning process" document for detailed descriptions of digital outputs. Note that the Sel0 and Sel1 lines are sampled each time a remote control frame is received: The output behaviour is not part of the learning procedure.

• Remote control acknowledgement

The transmission of an acknowledgement to the remote control depends on the registers 214 and 215 of the receiver. Registers are described at chapter "Register description" of this document and the way to access them at the "commands" chapter.

The register 214 sets the mode of acknowledgement: Automatic or Manual.

- When Auto acknowledgement is selected, the receiver automatically sends back an acknowledgement to the remote control. In this case, the type of acknowledgement is defined by the register 215: It defines the colour (red or green) and the kind of LED blink on the remote control.
- When Manual is selected, the acknowledgement must be received on the RxD serial line of the module. The format is the following: :<serial number> <acknowledge type><CR> The acknowledgement type value set is identical to the set of value of register 215.

If Manual is selected, the acknowledgement must be sent in a maximal delay time of 2s. After that, the acknowledgement generated will be lost.

To preserve the remote control battery life, it is recommended to send back the acknowledgement in the shortest possible delay. As soon as the remote control has

received its acknowledgement, it can be re-entered a very low power mode. For this same reason, it is mandatory to send an acknowledgement to the remote control.

• Remote control serial number update

The remote control serial number can be updated by radio link and serial lines. When performing this operation, the automatic acknowledgement feature must be deactivated (see register 214).

After that, the serial number can be updated by sending the following command in response of a remote control key pressed:

```
:<current serial number> 30 <new serial number><CR>
```

Any key can be pressed to start updating the remote control serial number. When the operation is successfully completed, the remote control sends a special long red blink on its LED.

Important note:

The new serial number must be set on the range 14 680 064 < Serial number < 16 777 214.

• Serial link configuration

Asynchronous serial link is fully configurable by registers 210, 211, 212, 213. Refer to “Registers description” chapter for details. By default, the serial link is configured to 9600 bps, no parity, 8 data bits, 1 stop bit.

LEARNING MODE

The learning mode procedures are fully described in the “ARF18 remote control learning process” document.

The learning process can be entered either by using a switch connected to switch inputs of the module or by using AT commands. AT commands to use are described in the “ARF18 remote control learning process” document. The AT command syntax is described in chapter “Commands” of this document.

When the transceiver is in learning process mode (add/remove function or erase), the acknowledgement (double blink green) is automatically generated by the module and no acknowledgement should be provided on the serial link.

COMMANDS

Commands are used to read and update the decoder parameters:

A frame starts with the 2 ASCII ‘AT’ characters. ‘AT’ means ‘Attention’ followed with one or several characters or other data.

Each command is ended with <CR> (carriage return).

Note: While the command is not ended by a <CR> or the receiver buffer is not full, the command is not interpreted. There is no maximal delay time to respect between 2 characters.

The response sent by the serial decoder to each command on the serial link corresponds to the ASCII character 'O' for an accepted command and ASCII character 'E' for error.

SET OF COMMANDS

Commands	Register management
ATSn?	Display the Sn register content where n represents the register number. The response has the following format: Sn=y<cr><lf>
ATSn=m	Set the Sn register value with 'm'. n represents the register number (example, selection of channel1: ATS200=1).
AT/S	Display registers value. The response has the following format: Sxxx=y<cr><lf> for each registers.
AT/V	Software version display. The response has the following format: Adeunis RF : Two-way smart remote control receiver I V0.01<cr><lf>
ATR	All the registers are initialised with their default value
AT&W	To save the new configuration in EEPROM. Each time you switch on the serial decoder, the EEPROM configuration will be loaded in the serial decoder registers.

REGISTERS DESCRIPTION

The register value could be updated using the ATSn=m<cr> command and displayed using ATSn?<cr> command.

The value of the registers is saved in RAM. The parameters are lost in case of power shutdown. To save the registers, it is necessary to use the AT&W<cr> command.

Access	Registers	Function	Description
<i>Serial link parameters</i>			
R/W	S210	Baudrate	Serial link data rate: '1' : 1200 bits/s '2' : 2400 bits/s '3' : 4800 bits/s '4' : 9600 bits/s (default value) '5' : 19200 bits/s '6' : 38400 bits/s '7' : 57600 bits/s
R/W	S211	Data length	Number of bits '7' : 7 bits '8' : 8 bits (default value)
R/W	S212	Parity	Parity '1' : none (default value) '2' : even '3' : odd
R/W	S213	Number of Stop bits	Number of stop bits (serial link) '1' : 1 stop (default value) '2' : 2 stops
<i>Acknowledgement parameters</i>			
R/W	S214	Acknowledgement mode	Mode '1' : Automatic acknowledgement generated by module (default value) '2' : Manual acknowledgement received on module Rx line.

R/W	S215	Acknowledgement type	Type '1' : 3 remote control green led blink (default value) '2' : 3 remote control red led blink '3' : 2 remote control green led blink '4' : 2 remote control red led blink
Learning procedure selection			
Refer to "ARF18 Remote control learning process user guide" for this set of registers.			

SPECIFICATIONS

• General characteristics

Parameters	Nominal values	Notes
Frequency	869.525 MHz	-
Power supply (VCC)	2.7 to 3.6 V	(Max rating = 4V)
Digital outputs characteristics		
Maximal load current per I/O	6 mA	-
VOH	from VCC-0.6 to VCC	-
VOL	from VSS to VSS +0.25	-
Digital inputs characteristics		
VIH	from 0.8 VCC to VCC	-
VIL	from VSS to VSS +0.6	-
Size (mm)	29 x 25 x 4	-
Operating temperature	-20 to +70 °C	-

• Transmitter characteristics

Parameters	Nominal values	Notes
Typical modulation	FSK 50 kHz	-
Power RF level (under 50Ω)	8 mW	-
Current consumption	< 17 mA	< 3V

• Receiver characteristics

Parameters	Nominal values	Notes
Sensitivity	< -104 dBm	-
Current consumption (permanent listening)	< 12.5 mA	< 3V

• Reference

ARF18	ARF7294B
-------	----------

STANDARD COMPLIANCE

When using transmitter and receiver sub-assemblies, the standard compliance relates to the finished equipment.

In Europe, the equipment has to comply to the RTTE directive. For this kind of Low Power applications, the RTTE directive compliance will be established with respect of:

- EN300-220 radio standard.
- EN301-489 ECM standard.
- EN60950 Electric security (when usable).

Important:

Though ARF7294 daughter boards comply with the limits of the EN300-220 radio standard, their integration inside a mother board may change some radioelectrical characteristics. (Harmonic levels, R.F leakage...)

The final equipment, before the laboratory testing, has to be examined at the ADEUNIS RF lab to check its compliance. After official testing, equipment and test reports have to be archived to justify the compliance.