

ARF18 ARF7263J/K/R/S User Guide

Remote control receiver (serial / USB)

DECLARATION OF CONFORMITY	2
PRESENTATION	3
PRODUCT INSTALLATION	3
USB WIRING AND DRIVER INSTALLATION	4
<i>For the first connection</i>	4
<i>For every new connection</i>	4
<i>Supply voltage</i>	4
SERIAL LINK WIRING	5
<i>Connect the receiver as a DTE on RS232</i>	5
<i>Connect the receiver as a DCE on RS232</i>	5
<i>Supply voltage</i>	5
ANTENNA WIRING	6
COMMAND MODE	7
COMMANDS	7
SET OF COMMANDS	7
REGISTERS DESCRIPTION	7
NORMAL MODE	8
TECHNICAL DATA	9
<i>General presentation</i>	9
<i>Product references</i>	9

DECLARATION OF CONFORMITY

according to ISO/IEC Guide 22 and EN45014



Manufacturer's name: **ADEUNIS R.F.**

Manufacturer's address: Parc technologique PRE ROUX IV
283 rue Paul Louis NEEL
38920 CROLLES - FRANCE

declares that the product

Product Name: ARF18
Product Number(s): ARF7263J/K/R/S
Product options:

conforms to the RTTE Directive 99/5/EC:

EMC:
conformity is proven by compliance to the standard EN 301489 according to the requirements of EMC Directive 89/336/EEC.

Safety:
conformity to the standard EN 60950 according to the requirements of Low Voltage Directive 73/23/EEC.

Radio:
conformity is proven by compliance to harmonised standard EN 300220 covering essential radio requirements of the RTTE directive.

Notes:
- Conformity has been evaluated according to the procedure described in Appendix III of the RTTE directive.
- The use of the spectrum is harmonised by the fact that the product never falls under one of the restrictions listed in appendix 3 (Appendix 1, band E) of the CEPT recommendation 70-03.
- Receiver class (if applicable): 2.

Crolles, November 4th, 2005

VINCENT Hervé / Quality manager

PRESENTATION

The ARF7263J/K/R/S radio receiver converts radio frame coming from a remote control transmitter.

The ARF7263J/K sends the remote control information on the RS232 serial link. The ARF7263R/S is doing the same by the emulation of a COM port over the USB bus.

The operating parameters of the ARF7293 (RS232 serial link) can be updated through AT commands via the RS232 serial link. The default settings are 9600, 8, n, 1.

The products are available either in board version to be integrated in an assembly, or standalone in an IP65 housing.



PRODUCT INSTALLATION

The ARF7263J/K/R/S receivers are fixed by the fixing lugs onto the top (antenna) and bottom (stuffing box) parts of the housing. Any operation (drilling...) performed on the housing makes it lose its IP65 tightness rating.

Remove the two stainless steel screws (A and B) and take the bottom part off to access the power supply terminal blocks and contacts.

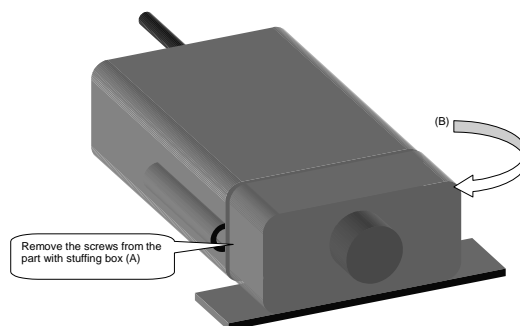

USB WIRING AND DRIVER INSTALLATION

This chapter applies for USB version of the remote control receiver.

- **For the first connection**

On first connection to the PC, the user is prompted for USB driver installation. Refer to our "USB driver installation guide" to process.

- **For every new connection**

This receiver is seen as a virtual serial COM port available via the USB bus. The user has to query the serial COM port number affected to the receiver to be able to communicate with it. Please, refer to our "USB driver installation guide" to get the COM port serial number.

Important note:

If the receiver was previously connected on your PC, be sure it has not been disconnected without closing the terminal session. In such a case, the driver would appear has badly installed in the windows peripheral manager - this is shown by the "!" icon. If this situation appears, close the terminal session previously opened on the tool, disconnect the remote control receiver and then restart the connection procedure.

- **Supply voltage**

The remote control receiver is self powered and does not require any external power.

SERIAL LINK WIRING

This chapter applies for RS232 version of the remote control receiver.

- Connect the receiver as a DTE on RS232

This is for example the case of a remote control receiver connected to a PC.

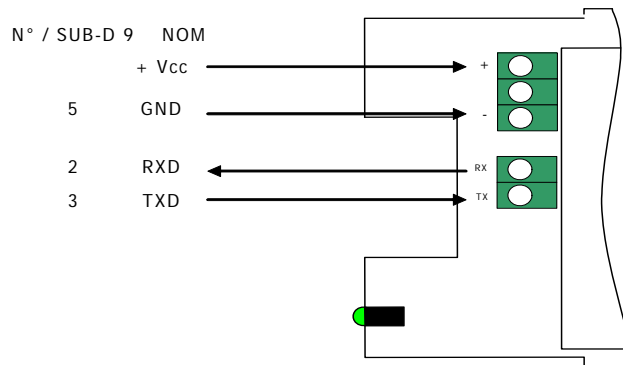

- Connect the receiver as a DCE on RS232

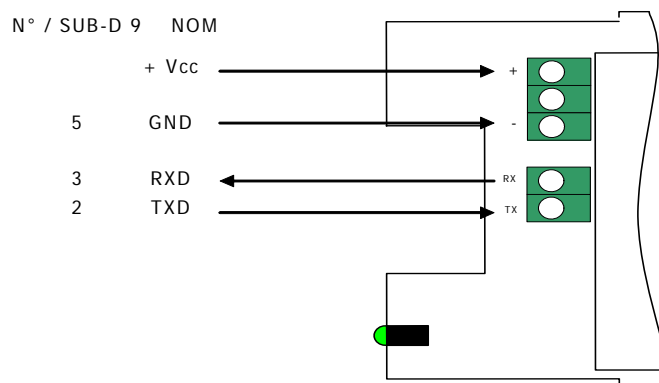

- Supply voltage

Turn off the voltage supply, then wire the power supply up to the screw terminals marked + and -.

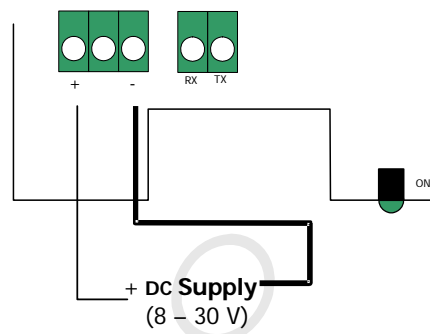

ANTENNA WIRING

In daughter-board version, an antenna has to be added to achieve correct communication between the products.

This antenna should be a wire with a length of $\frac{1}{4}$ wave, i.e. about 17 cm. This length is that which has to extend outside the housing if the latter is metallic.

This antenna can be located remotely using a coaxial cable with its braid stripped over the last 17 centimeters.

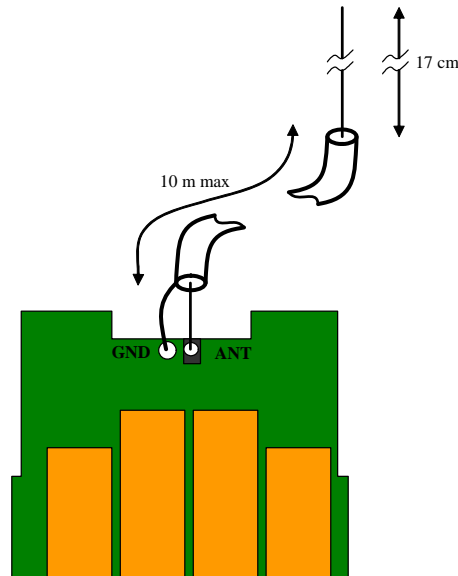

COMMAND MODE

When delivered the receiver is fully operational (default factory configuration is 9600,n,8,1).

Nevertheless the module parameters can be customised using the serial input (RS232 or USB) which is dedicated for the AT commands. These commands can be sent from a terminal (with a delay between each character lower than 10 seconds).

The command mode is used to read and update the module configuration registers. The registers are shared in 2 types: write only (W) or read/write (R/W) (see chapter. « registers description » document)

COMMANDS

A command starts with the 2 ASCII 'AT' characters. 'AT' means 'Attention' followed with one or several characters or other data.

Each command must be ended with <cr> (carriage return, ASCII code 0x0D).

The response sent on the serial output for each command corresponds to the ASCII character 'O' for an accepted command and ASCII character, 'E' for error.

SET OF COMMANDS

Commands	Register management
ATSn?	Display the Sn register content where n represents the register number. The response has the following format: Sn=y<cr><lf>
ATSn=m	Set the Sn register value with 'm'. n represents the register number (example, selection of number of stop bits: ATS213=1).
AT/S	Display registers value. The response has the following format: Sxxx=y<cr><lf> for each register.
AT/V	Software version display. The response has the following format: Adeunis RF : One way smart remote control receiver I Vx.yy<cr><lf>
ATR	All the registers are initialised with their default value
AT&W	To save the new configuration in EEPROM. Each time you switch on the serial receiver, the EEPROM configuration will be loaded in the serial receiver registers.

REGISTERS DESCRIPTION

The register value can be updated using the ATSn=m<cr> command and displayed using ATSn?<cr> command.

The value of the registers is located in RAM. The parameters are lost in case of power off. To save the registers, it is necessary to use the AT&W<cr> command.

Access	Registers	Function	Description
	<u>Serial link</u>		
R/W	S210	Baudrate	Serial link data rate: '2' : 2400 bits/s '3' : 4800 bits/s '4' : 9600 bits/s (default value) '5' : 19200 bits/s '6' : 38400 bits/s '7' : 57600 bits/s '8' : 115200 bits/s
R/W	S211	Data length	Number of bits '7' : 7 bits '8' : 8 bits (default value)
R/W	S212	Parity	Parity '1' : none (default value) '2' : even '3' : odd
R/W	S213	Number of Stop bits	Number of stop bits (serial link) '1' : 1 stop (default value) '2' : 2 stops

NORMAL MODE

During normal operation, the module sends on the serial output the serial number and the key number of remote control received on its radio link. The format of the ASCII received frame is the following:

:<serial number> <Key number> <CR><LF>

- : (ASCII code 0x3A)
- Serial number is the remote control serial number in decimal format (1 to 8 digits)
- Followed by a space (ASCII code 0x20)
- Key number is the key pressed number of the remote control (2 digits from 01 for key 1 up to 24 for key 24)
- CR (ASCII code 0x0D), LF (ASCII code 0x0A)

TECHNICAL DATA

• General characteristics

Parameters	Nominal values	Notes
<i>Radio characteristics</i>		
Frequency	433.92 MHz	-
Modulation	ASK	-
Sensitivity	-104 dBm	-
<i>Electrical characteristics(RS232 products)</i>		
Power supply (VCC)	8 to 30 V _{DC}	-
Consumption (Rx permanent listening)	16mA	Under 8V
<i>Electrical characteristics(USB products)</i>		
Power supply (VCC)	Powered by USB bus	-
Consumption (Rx permanent listening)	32mA	-
<i>Mechanical characteristics</i>		
Size (mm)	Board: 65 x 90 x 25mm Ip65 box: 104 x 300 x 35mm	-
Operating temperature	-20 to +70 °C	-

• Product references

- ARF7263J: RS232 remote control receiver board
- ARF7263K: RS232 remote control receiver in IP65 housing
- ARF7263R: USB remote control receiver board (self powered)
- ARF7263S: USB remote control receiver in IP65 housing (self powered)
- ARF7291A: 1-key remote control
- ARF7291B: 2-key remote control
- ARF7291C: 3-key remote control
- ARF7291D: 4-key remote control
- ARF7291R: 8/24-key remote control